

CAGE DUMP STATION

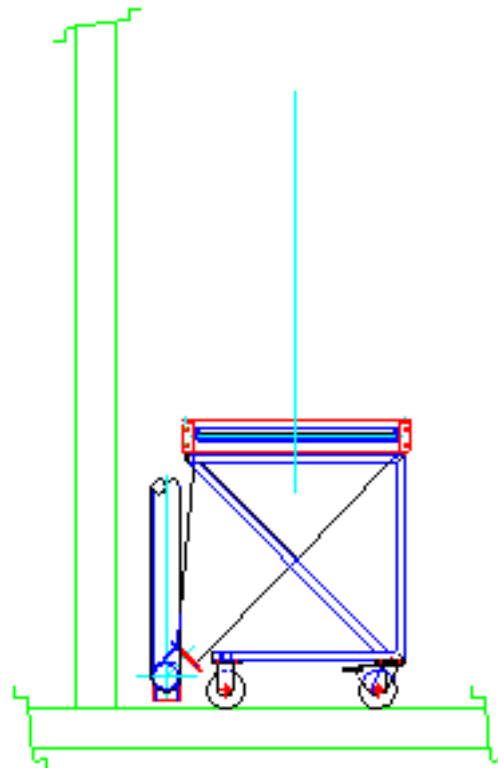
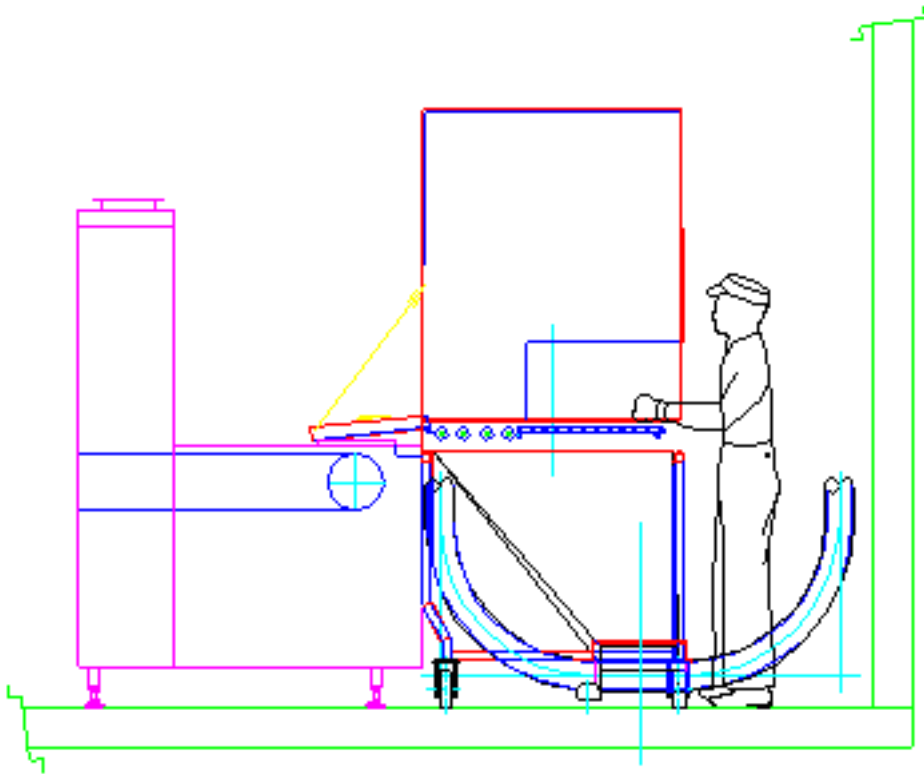

Technical Details

- Receiving hopper assembly of #304 stainless steel wash-down construction. Sized to interface with the tunnel washer (by others). Complete with adjustable support assembly and vibrator mounting pad.
- Dump station gravity roller conveyor manufactured in #304 stainless steel and mounted in hopper. The roller conveyor will interface with the tunnel washer inlet so that the cages can flow from the roller conveyor into the tunnel washer.
- Clean air hood, complete with 99.99% efficient water resistant HEPA filter and carbon filter. Includes protective filter grill and airflow control valve. Stainless steel wrap to mate with hopper.

Optional Equipment

- Powered roller conveyor section mounted in place of gravity roller conveyor section to interface with the washer conveyor.
- Electric vibrator mounted to exterior sloped wall of the hopper. 115v with "on/off" switch.

Contact



6407-36 Avenue, Edmonton, AB, Canada T6L 1E9
M (780) 430-4225 T (877) 441-4225
F (780) 430-4229